

## DATENBLATT / FACT SHEET



ART.-NR:	FARBTEMPERATUR:
009-953	2700 K
004-886	3000 K
009-954	4000 K

**MODUL Q 144**

DECKENLEUCHTE / CEILING LUMINAIRE

Extrem flache, nur 10 mm hohe LED.next Deckenleuchte für Direktmontage. Lichtaustritt vorwiegend (ca. 98%) direktstrahlend, breit abstrahlend. Zusätzliche Deckenaufhellung, sowie sehr gleichmäßige, nahezu raumhohe Wandaufhellung durch Sekundärlicht. Externer Nimbus-Konverter erforderlich. Der Konverter kann in die abgehängte Decke eingelegt werden.

Ultra flat 10 mm thick ceiling LED.next luminaire for direct mounting. Beam mainly direct (approx. 98%), wide beam. Additional ceiling lighting and also a very even, almost floor-to-ceiling illumination of walls by secondary light. External Nimbus converter required. The converter can be integrated in a suspended ceiling.

31 W LED.next ≈ 200 W Halogen

31 W LED.next ≈ 200 W halogen

## TECHNISCHE DATEN / TECHNICAL FACTS

**Artikel:**

Modul Q 144

**Art.-Nr.:**      **Farbtemperatur:**

009-953      2700 K

004-886      3000 K

009-954      4000 K

**Beschreibung/ Ausführung:**

Deckenleuchte für Direktmontage

**Hersteller:**

Nimbus Group GmbH

Siegelerstr. 41, D-70469 Stuttgart

Tel.: +49(0)711 / 63 30 14 - 20

Fax: +49(0)711 / 63 30 14 - 14

info@nimbus-group.com

www.nimbus-group.com

**Abmessungen:**

320 x 320 x 10 mm

**Material:**

Diffusorfläche: Acrylglas

Aufhängung: Stahl

**Gewicht:**

ca. 1643 Gramm

**Lichttechnik:****LED.next**-Technologie integriert**Anschluss-Leistung:**

31 W / 24 Volt DC

**Anzahl LEDs:**

144 Stück

**Schutzart:**

IP 20

**Lichtstrom:**

2502 lm

**Abstrahlcharakteristik:**

breit abstrahlend

**Lichtverteilung:**

98 % direktstrahlend

**RA:**

80

**Prüfzeichen:****Reinigungs- und Pflegehinweise:**

Leuchte beim Reinigen vom Netz trennen. Keine ätzenden oder abrasiven Reinigungsmittel verwenden. Wir empfehlen, die Leuchte nur mit einem Microfasertuch o. ä. trocken zu reinigen.

**product:**

Modul Q 144

**product no.:**      **colour temperature:**

009-953      2700 K

004-886      3000 K

009-954      4000 K

**description/design:**

ceiling luminaire for direct mounting

**manufacturer:**

Nimbus Group GmbH

Siegelerstr. 41, D-70469 Stuttgart

Tel.: +49(0)711 / 63 30 14 - 20

Fax: +49(0)711 / 63 30 14 - 14

info@nimbus-group.com

www.nimbus-group.com

**dimensions:**

320 x 320 x 10 mm

**materials:**

diffusor surface: acrylic glass

mounting: steel

**weight:**

approx. 1643 grams

**light technology:****LED.next**-technology integrated**required power supply:**

31 W / 24 volts DC

**number of LEDs:**

144 pcs

**degree of protection:**

IP 20

**luminous flux:**

2502 lm

**directional characteristics:**

wide beam

**light distribution:**

98 % direct beam

**CRI:**

80

**certificates:****cleaning and care:**

Switch off luminaire while cleaning. Do not use any corrosive or abrasive cleanser. We recommend to clean the luminaire with a dry microfibre towel only.

## LICHTVERTEILUNGSKURVE UND ABSTRAHLCHARAKTERISTIK / LIGHT DISTRIBUTION CURVE AND DIRECTIONAL CHARACTERISTIC

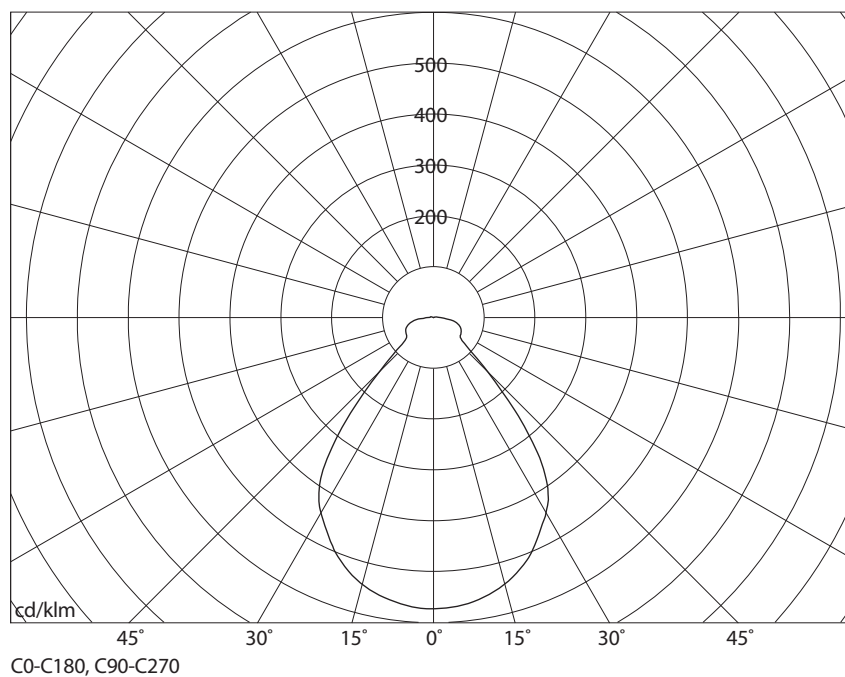

Lichtberechnungsdaten (EULUMDAT) unter [www.nimbus-group.com](http://www.nimbus-group.com)

## ISOMETRIE UND MASSE / SIZES

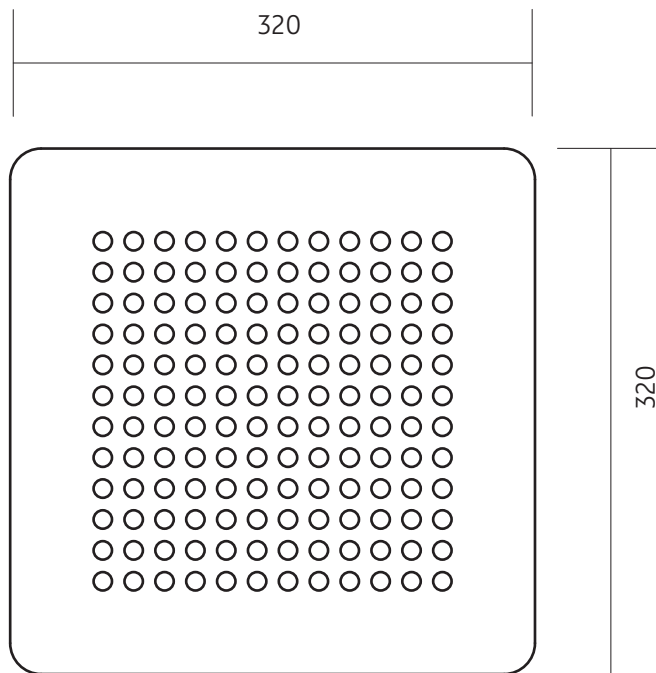
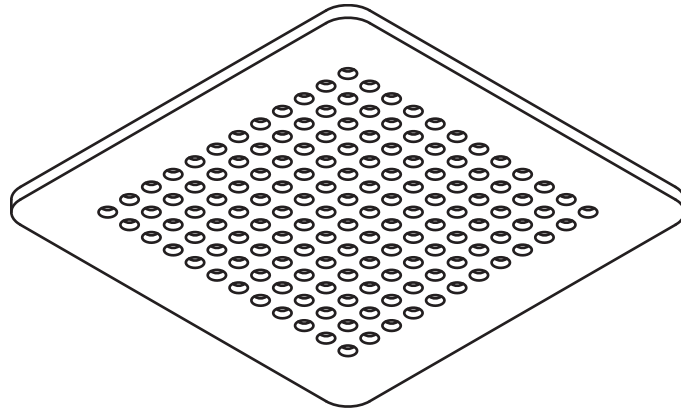

**MODUL Q 144 LED.next**  
DECKENLEUCHTE / CEILING LUMINAIRE

**nimbus<sup>x</sup>**

004-886 . 009-953 . 009-954

FÜR DIREKTMONTAGE (ABGEHÄNGTE DECKE)  
FOR DIRECT MOUNTING (SUSPENDED CEILING)

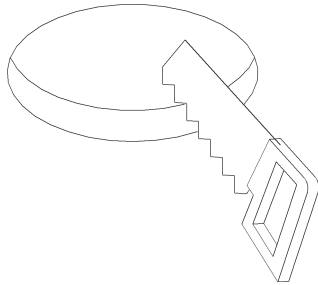
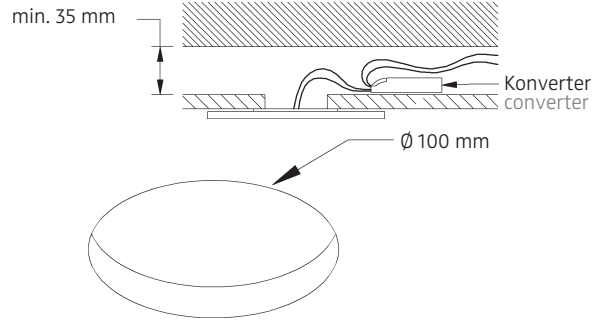

1

2

Anschluss an 230V AC  
connection to 230V AC

Anschluss an 24V DC  
connection to 24V DC

Anschluss an 230V AC  
connection to 230V AC

Anschluss an 24V DC  
connection to 24V DC

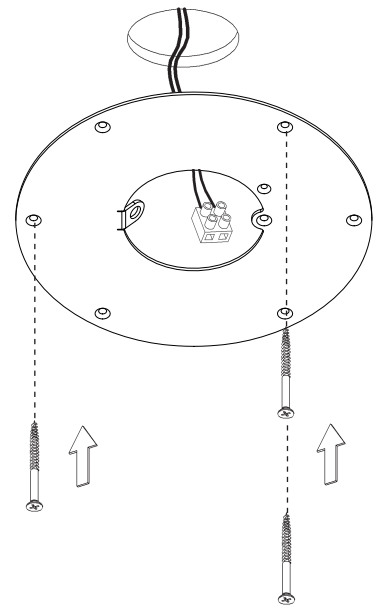
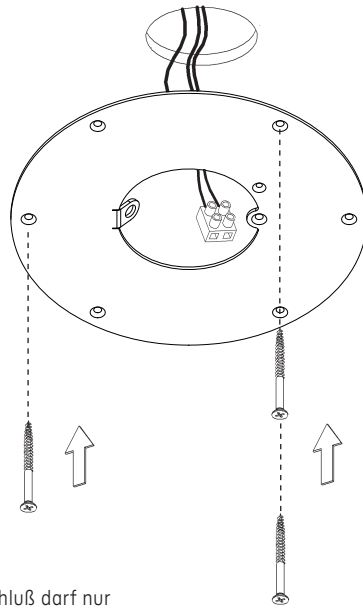
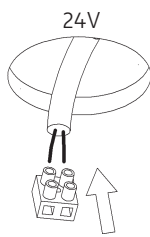
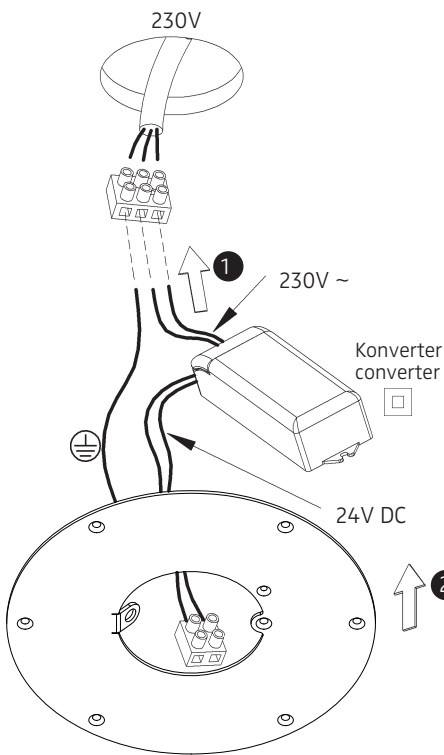

3

4

⚠ Der elektrische Anschluß darf nur vom Fachmann ausgeführt werden!  
Must be installed by a qualified electrician only!

Sicherungsseil an Lasche befestigen!  
Click safety rope into plate!

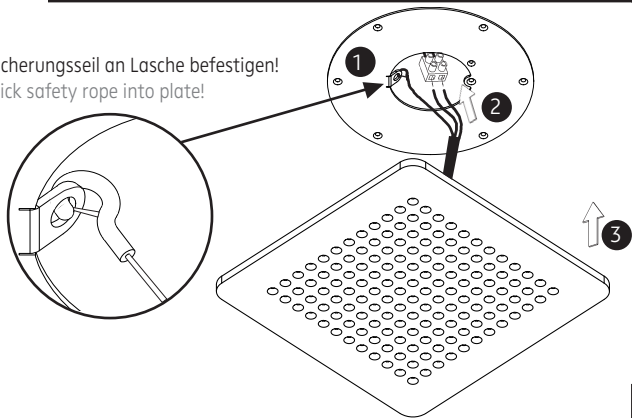

5

6

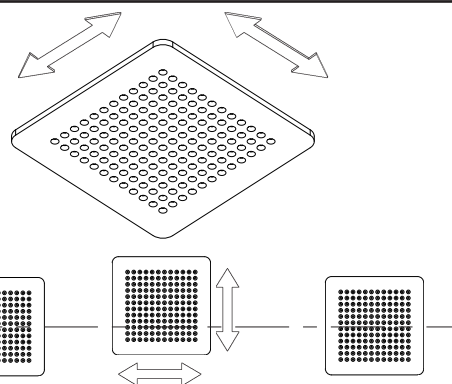

004-886 . 009-953 . 009-954

24V , Konstantspannung  
24V , constant voltage

Bestückung: LED.next 31W  
lamp type: LED.next 31W

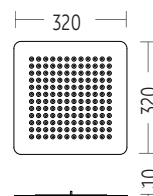

Schutzart IP 20  
protection degree IP 20

Deckenmontagering für Q / R 100 und 144:

